



OWNERS MANUAL

BULK MATERIAL SPREADER

This unit may have been built with special features.
Please provide serial number when ordering parts.

Serial Number: _____

Model Number: _____

Purchase Date: _____

MFG by: Stoltz Mfg., LLC
121 Morgan Way
PO Box 527
Morgantown, PA, USA 19543
Tel: (610) 350-4322

TABLE OF CONTENTS

WARRANTY

- Warranty Claim Procedure
- Warranty Registration Form

SAFETY NOTICE

SECTION I: Specifications

SECTION II: Preparation For Use

SECTION III: Spreader Hookup and Operation

SECTION IV: Loading Your Spreader

SECTION V: Operating Your Spreader

SECTION VI: Calibrating Your Spreader

SECTION VII: Application Rate Calculations

SECTION VIII: Lubrication and Maintenance

SECTION XIV: Replacement Parts

SECTION XV: Options/Custom Components (If Applicable)

LIMITED WARRANTY

Stoltz Mfg., LLC warrants, for six months from the date of purchase, to the original owner, that each spreader is free from defects in either material or workmanship, provided that it has been adequately maintained and used under normal operating conditions.

This warranty covers only those items, parts and assemblies manufactured by Stoltz Mfg., LLC. Parts manufactured by others carry only the warranty offered by the original manufacturer.

Stoltz Mfg., LLC's obligation under this warranty is limited to correcting the defect, without charge, at its factory or as arranged by its Dealer. Before acceptance of any warranty claim, the item must be examined by Stoltz Mfg., LLC and must be found to have been defective. The defective item may be replaced or repaired to fulfill the obligations of this warranty.

This warranty shall not apply to any items damaged through misuse, abuse, accident, repair, overloading or lack of adequate maintenance.

This warranty shall not apply to any items that are worn through normal use. All items that are considered as normal maintenance will not be covered by this warranty, nor will damage caused by failure to perform maintenance. This includes tightening of nuts, bolts, clamps, set screws, etc. **Damage caused by loose fittings is not covered by warranty.**

Stoltz Mfg., LLC shall under no circumstances be liable for any incidental or consequential damages arising from loss of property or other damages or losses owing to the failure or use of Stoltz products beyond the cost of repair or replacement of any defective part.

Stoltz Mfg., LLC makes no warranty of fitness or merchantability. No other warranty, expressed or implied, is made by Stoltz Mfg., LLC beyond the terms expressed herein.

No person, agent or dealer is authorized to give any other warranty on the behalf of Stoltz Mfg., LLC.

WARRANTY CLAIM PROCEDURE

1. Contact Stoltz Mfg., LLC directly or your dealer. Obtain a Return Goods Authorization (RGA) number. Your purchase date and serial number will be required.
2. In certain cases, you will be required to return the part or the entire spreader to Stoltz or its dealer for inspection.
3. When parts are returned for inspection, you will be required to pre-pay the freight charges.
4. If parts are shipped by Stoltz Mfg., LLC before a valid warranty request has been accepted, you will be invoiced by Stoltz for the parts. The issuance of an RGA number does not guarantee that the request will be granted.

You must complete and return the Warranty Registration form below within 2 weeks of the purchase date.

NOTE: Read enclosed SAFETY NOTICE before submitting.

Cut Here-----Cut
Here

Warranty Registration Form		
Return to:		
Stoltz Mfg., LLC PO Box 527 Morgantown, PA 19543		
Please Print or Type:		
Name _____		
Address _____ _____		
City: _____	State: _____	Zip: _____
Phone: _____		
_____	_____	_____
Model Number	Serial Number	Purchase Date
I hereby confirm that I have read the enclosed SAFETY NOTICE.		
Owners		
Signature: _____		Date: _____
Print Name: _____		

SAFETY NOTICE

The buyer assumes all responsibility for the safe use of this product, as well as the materials spread with it.



This symbol is used to call attention to instructions concerning personal safety. Be sure to observe and follow these instructions.



WARNING: BEFORE ATTEMPTING TO OPERATE THIS SPREADER, READ AND STUDY THE FOLLOWING SAFETY INFORMATION. IN ADDITION, MAKE SURE THAT EVERY INDIVIDUAL WHO OPERATES OR WORKS WITH THE SPREADER IS FAMILIAR WITH THESE SAFETY PRECAUTIONS.



This spreader is intended for off-road usage. Stoltz recommends transporting the spreader between job sites on a trailer. It is the operator's responsibility to ensure that all federal, state, and local safety regulations are adhered to and that over-width permits are obtained if necessary.



WARNING: UNDER NO CIRCUMSTANCES SHOULD THE SPREADER BE TRANSPORTED LOADED ON PUBLIC ROADS.



WARNING: THIS SPREADER IS INTENDED TO PROPEL GRANULAR MATERIALS THROUGH THE AIR AT HIGH SPEEDS! SUCH FLYING MATERIALS MAY BE HAZARDOUS TO PEOPLE, CROPS AND ANIMALS

- **DO NOT STAND BESIDE OR BEHIND SPREADER WHILE IN OPERATION**
- **DO NOT SPREAD MATERIAL INTO A CROP THAT MAY BE DAMAGED**
- **DO CHECK THE LOCATION OF OTHER PERSONS BEFORE STARTING**
- **DO CHECK THE FLIGHT PATH OF MATERIALS FOR POSSIBLE IMPACT ON STANDING CROPS OR OTHER PEOPLE**
 - **DO CHECK THE SPREAD PATTERN FOR UNIFORMITY**



DO NOT operate, service, inspect or otherwise handle this spreader until all operators have read this Owner's Manual and have been properly trained in the intended usage of the spreader.



Cover all loads that can spill or blow away. Do not spread dusty materials where dust may create pollution or a traffic visibility problem.





Do not allow minors (children) or inexperienced persons to operate this spreader.





If the spreader becomes clogged, shut off the tractor engine and allow all mechanisms to stop. Relieve hydraulic pressure. Disconnect PTO shaft and hydraulic hoses. Then take

the unit back to the shop or a safe place to clean or work on the spreader as required. Never attempt to pull material from any part of the equipment while it is running.

 Always shut off power, block the wheels, disconnect the PTO drive shaft, and unhook hydraulic hoses from the tractor to prevent accidental startup or unexpected movement before working on the machine.

 The hydraulic system and oil can get hot enough to cause burns. Wait until oil has cooled before working on the system.

 Some parts and assemblies are quite heavy. Before attempting to unfasten any heavy part or assembly, arrange to support it by means of a hoist, by blocking or by use of an adequate arrangement to prevent it from falling, tipping, swinging or moving in any manner which may damage it or injure someone. Always use lifting devices that are properly rated to lift the equipment. Do not lift the loaded spreader. Never lift equipment over people.

 If repairs require use of a torch or welder, be sure that all flammable and combustible materials are removed. Fuel or oil reservoirs must be emptied, steam cleaned, and filled with water before attempting to cut or weld them. DO NOT weld or flame cut on any tank containing oil, gasoline, their fumes, or other flammable material, or any container whose contents or previous contents are unknown.

 Make sure that material is not concentrated at the rear of the machine before unhitching. Material at the rear of the machine may cause the trailer hitch to tip upward.

 Read and understand the precautionary decals on the spreader. Replace any that become defaced, damaged, lost or painted over. Replacement decals can be ordered from your dealer's parts department or from Stoltz by calling 610-350-4322.

 Do not clean, adjust, or lubricate while spreader is in motion.

 Turn slowly and be careful when traveling on rough surfaces and side slopes, especially with a loaded spreader, as the load may shift causing the unit to tip.

 Never allow anyone to ride on any part of the spreader for any reason. Stay out of the hopper while the conveyor is running.

 Do not stand on the spinner guard

















 Make sure that all hydraulic fittings are tight and that all hoses are in good condition. Hydraulic fluid escaping under pressure can have sufficient force to penetrate skin and cause serious injury. Never investigate for hydraulic leaks by using a part of the body to feel for escaping fluid.

 Inspect the unit regularly to ensure that all connections and bolts are tight and secure before operating.

 Know how to stop the spreader before starting it.

 Do not operate the unit unless all shields, covers, and guards are in place.

 Make certain that everyone is clear of the spreader before applying power.

-  Keep hands, feet and clothing away from moving parts. Loose or floppy clothing should not be worn by the operator.
-  Do not insert a stick, tool or hands into conveyor, spinners or other moving parts
-  Stay well clear of the spreader's spinners while operating.
-  Do not breathe the dust when spreading dusty materials. Wear a dust mask or other approved respiratory device.
-  Do not climb on any part of the spreader at any time. Do not use the PTO guard as a step.
-  Do not step over the PTO shaft. Stay clear of the PTO at all times.
-  If the unit is equipped with a ladder, be careful in getting on and off the ladder, especially in wet, icy, snowy or muddy conditions. Clean mud, snow or ice from steps and footwear.
-  Keep PTO shaft telescoping tube shields turning freely. Keep PTO master shield on tractor. Replace any shields that are missing or damaged.
-  Never operate the PTO above the normal RPM rating. The tractor's PTO MUST match the implement PTO.
-  Install controls so that they are located for convenient use. Position them so that they do not interfere with any vehicle control, with driver or passenger mobility or with access to or from the vehicle.
-  Do check the spread pattern to ensure that you are getting a uniform pattern.
-  Use only properly rated tires.
-  Do not tow at speeds in excess of 20 MPH when transporting this spreader. Never exceed a safe travel speed.
-  Observe all applicable traffic laws when transporting on public roadways (where legal to do so). Check local laws for all highway lighting and marking requirements.
-  Always install a SMV emblem on this spreader for transporting on roadways and keep the emblem clean and bright.
-  The buyer assumes all responsibility for the safe use of this product, as well as the materials spread with it. If you have any questions regarding the safe and proper use of this spreader or options and attachments, please contact your dealer or the manufacturer at 610-350-4322.



**CAUTION: DO NOT WELD ON SPREADER WITHOUT
UNHOOKING ALL ELECTRONICS FIRST !!!**



**WARNING: DO NOT OPERATE ON SIDE SLOPES
EXCEEDING 10 DEGREES (5:1 SLOPE) WITH A FULL LOAD.
THIS VEHICLE HAS A VERY HIGH CENTER OF GRAVITY.**

**STOLTZ MFG., LLC PROVIDES GUARDS FOR EXPOSED MOVING PARTS FOR
THE OPERATOR'S PROTECTION. HOWEVER, SOME AREAS CANNOT BE
GUARDED OR SHIELDED IN ORDER TO ASSURE PROPER OPERATION. THE
OPERATOR'S MANUAL AND DECALS ON THE MACHINE ITSELF WARN YOU
OF DANGERS AND MUST BE READ AND OBSERVED CLOSELY.**

**STUDY THE ABOVE SAFETY RULES
FAILURE TO HEED MAY RESULT IN SERIOUS PERSONAL INJURY OF DEATH**

For questions, the manufacturer's toll free telephone number is:

1-800-843-8731

(Remember...Safety First)

SECTION I
SPECIFICATIONS

Bulk Material Spreader

	BMS 5010	BMS 8016	BMS 1516	BMS 1520
Max Rated Payload	5 ton	8 ton	15 ton	15 ton
Approx. Empty Wt.	3,700 lbs	5,000 lbs	5,700 lbs	6,700 lbs
Hopper Capacity	137 cu ft	225 cu ft	225 cu ft	400 cu ft
Hopper Capacity	110 bu	180 bu	180 bu	320 bu
Hopper Length	10 ft	16 ft	16 ft	20 ft
Hopper Width	74 in	74 in	74 in	84 in
Hopper Depth	37 in	37 in	37 in	49 in
Overall Length	18 ft	24 ft	24 ft	28 ft
Overall Width	79 in	94 in	102 in	102 in
Overall Height	71 in	78 in	78 in	89 in
Standard Tire Size	11Lx15	19Lx16.1	21.5Lx16.1	21.5Lx16.1
Optional Tire Size	13.5Lx15	21.5Lx16.1	NA	NA
Wheel Track	68 in	80 in	80 in	80 in
Hopper Material	Steel	Steel	Steel	Steel
Hopper Pan	CorTen	CorTen	CorTen	CorTen
Floor	HDPE	HDPE	HDPE	HDPE

SECTION II

PREPARATION FOR USE

Before operating, read this owners manual completely, paying particular attention to the safety warnings.

Inspection: Before putting your new spreader into service, take a few minutes to be sure it is in proper operating condition after shipment from the factory.

Use the following checklist:

1. Visually inspect the unit for obvious damage or any missing parts. Report any problems to Stoltz or your dealer immediately.
2. Check hydraulic fittings for possible leaks.
3. Check hydraulic hoses for possible chaffing.
4. Check belts and chains for alignment and tension.
5. Check for loose setscrews in bearings, sheaves and sprockets.
6. Check wheel bolt torque.
7. Check tire pressure (see recommendations on side wall).
8. Check conveyor chain tension. Chain should touch return track at approximately 18 inches behind front idler shaft. Both sides should be equal. Check again after spreading first load. Cotter pin must be in tightener bolt to prevent tightener from vibrating loose.
9. Check for any loose items or obstruction in hopper or on spinners, and run machine to be sure it moves freely.

Hydraulic Spinners (If Equipped):

Your spreader is compatible with both open and closed center tractors. Determine if your tractor has open or closed center hydraulics and then:

For Closed Center tractors, the ball valve must be closed (handle in horizontal position).
For Open Center tractors, the ball valve must be open (handle in vertical position)



Ball Valve Closed



Speed Control



Ball Valve Open

Note that spreaders with self-contained PTO hydraulics will not have this valve.

Spinner speed can be adjusted with the flow control valve. Normal spinner speed is 650-700 RPM, which usually can be achieved with this valve in the #9 position to send 15 gpm to the spinners. Note that tractor RPM must be high enough to pump 15 gpm to the spinners.

SECTION III

SPREADER HOOKUP AND OPERATION

Spreader Hookup: Fasten the spreader hitch to the tractor drawbar with a hitch pin that cannot bounce out. Use a 1" diameter hitch pin to pull the spreader. Secure the drawbar so that the hitch pin hole is located directly below the PTO drive line.



CAUTION: TIPPING HAZARD

MAKE SURE MATERIAL IS NOT CONCENTRATED AT THE REAR OF THE MACHINE BEFORE UNHITCHING. MATERIAL AT THE REAR OF THE MACHINE MAY CAUSE THE TRAILER TO TIP UPWARD.

Jack: Remove the weight from the jack (jack is not to be used when spreader is loaded). Lift the jack so that it will be out of the way.

PTO: Before operation and after hitching the tractor to the spreader, connect the PTO drive shaft to the tractor. Slide the spring loaded locking collar on the PTO yoke rearward, and slide the yoke onto the tractor PTO shaft. Release the spring loaded collar. Be sure the pins fall into the grooves of the tractor PTO shaft and that the collar snaps forward into the locking position. Fasten the PTO safety chain to the spreader to prevent rotation of the safety shield during operation.

This spreader must be operated with a 540 RPM PTO, unless specifically configured for a 1000 RPM PTO. The hitch of the spreader is designed for a standard tractor drawbar. Adjust the drawbar according to the diagram.

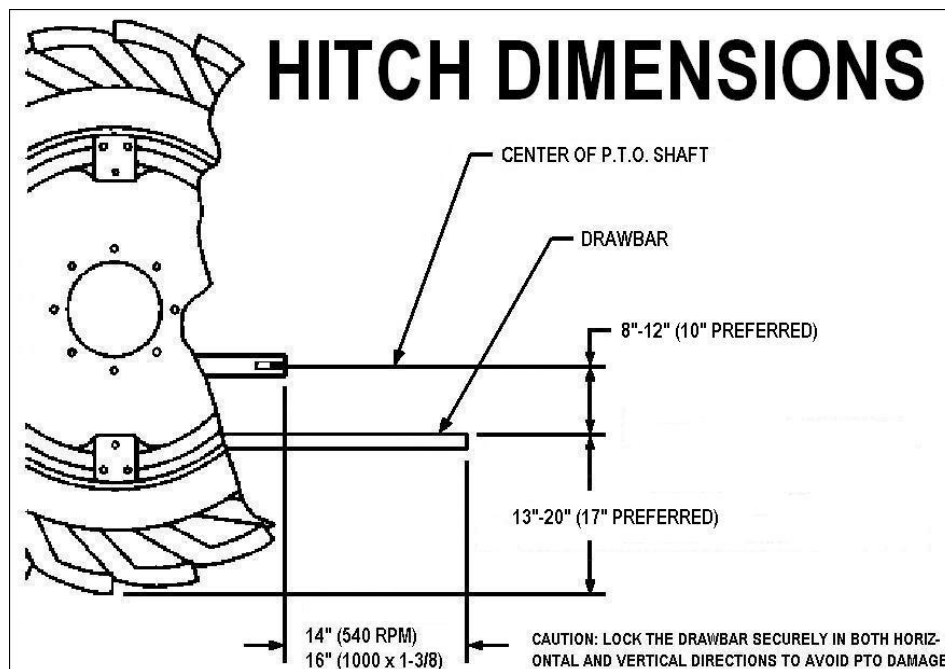

 **DANGER: DO NOT OPERATE WITHOUT PTO GUARD ON SPREADER AND ON TRACTOR. MAINTAIN PTO DRIVE SHAFT GUARD TUBES IN OPERATING CONDITION. REPLACE THEM IF DAMAGED AND NOT TURNING FREELY. FAILURE TO HEED MAY RESULT IN SERIOUS PERSONAL INJURY OR DEATH.**

Hydraulics: Route hydraulic hoses through the hose support rod which is mounted to the hitch frame. Connect the hydraulic hoses for the rear gate to the tractor's double acting valve hydraulic system. Move the tractor hydraulic controls to observe proper gate operation. If the controls operate the gate in the opposite direction to what you expect, reverse the hydraulic hose connections at the tractor.

 **WARNING: HYDRAULIC FLUID ESCAPING UNDER PRESSURE CAN HAVE SUFFICIENT FORCE TO PENETRATE SKIN. SUCH LIQUIDS HAVE A POISONOUS EFFECT AND CAN CAUSE SERIOUS WOUNDS. GET MEDICAL ASSISTANCE IF SUCH A WOUND OCCURS. TO CHECK FOR SUCH LEAKS, USE A PIECE OF CARDBOARD OR WOOD INSTEAD OF YOUR HAND.**

 **WARNING: THE FINE SPRAY FROM A SMALL HYDRAULIC OIL LEAK CAN BE HIGHLY EXPLOSIVE. DO NOT SMOKE, AND STAY AWAY FROM FLAME OR SPARKS. KEEP ALL HOSES AND CONNECTIONS IN GOOD SERVICEABLE CONDITION. FAILURE TO HEED MAY RESULT IN SERIOUS PERSONAL INJURY OR DEATH.**

Before loading the spreader, slowly engage the tractor PTO and operate machine at idle speed for several minutes to insure that the spreader is lubricated and operating properly.

Safety Chain: The safety tow chain must be used if the spreader is to be moved at any time on a public roadway. Be sure to adhere to all local/state transportation codes for travel on public roadways with this type of equipment.

For the safety chains to be effective, the installation of the chains should not allow more slack than is necessary for movement during spreader operation. Inspect the safety chains regularly to check the condition of the links and locking/hooks mechanisms. Replace the chains as if one or more links or end fittings are broken, stretched, or otherwise damaged or deformed. If the spreader is equipped with more than one safety chain they should be crossed under the tongue.

Drawbar: Regularly inspect the drawbar for wear and damage. If wear exceeds 1/8" (0.125"), replace the drawbar. Inspect the mounting fasteners and ensure they are properly tightened.

Tires/Wheels: Check wheel lug nuts upon delivery and daily thereafter (every 10 hours of use). Lug nuts should be tightened to 60-70 ft-lbs for 5 ton suspensions, 70-80 ft-lbs for 8 ton suspensions, and 250-265 ft-lbs of torque for 15 ton suspensions. Failure to do so may damage wheel nut seats. Once seats are damaged, it will become impossible to keep nuts tight. Check the tires and inflate to the pressure specified on the tire sidewall.

Walking Beam Travel: Do not bottom out suspension. Damage may occur to implement. The manufacture will not be liable for damage to implement due to improper usage.

Tractor Requirements: The loaded spreader should not weigh more than 1.5 times the weight of the tow vehicle. For hilly terrain, road travel, or other adverse conditions, tractor weight must be equal to gross loaded spreader weight. Do not tow spreader at speeds exceeding 20 mph (32 km/h). Operating speed is dictated by the terrain over which you are traveling. Always use caution. Avoid traveling on slopes or hills that are unsafe.



WARNING: DO NOT TOW SPREADER AT SPEEDS EXCEEDING 20 MPH (32 KM/H). FAILURE TO HEED MAY RESULT IN SERIOUS PERSONAL INJURY OR DEATH.



WARNING: OBSERVE ALL APPLICABLE TRAFFIC LAWS WHEN TRANSPORTING SPREADER ON PUBLIC ROADWAYS. CHECK LOCAL LAWS FOR ALL HIGHWAY LIGHTING AND MARKING REQUIREMENTS.



WARNING: INSTALL A SMV EMBLEM ON REAR OF SPREADER FOR TRANSPORTING ON ROADWAYS. KEEP THIS EMBLEM CLEAN AND BRIGHT. FAILURE TO HEED MAY RESULT IN SERIOUS PERSONAL INJURY OR DEATH.

If you will travel on public roads and it is legal to do so, you must know all rules governing such operation. This will include lighting and brake requirements in addition to traffic rules.



WARNING: PERFORM MAINTENANCE ON LEVEL SURFACE WITH WHEELS BLOCKED. THERE IS NO PARKING BRAKE ON THE SPREADER. BLOCK THE WHEELS PRIOR TO UNHITCHING OR PERFORMING ANY MAINTENANCE ON THE SPREADER. UNCONTROLLED MOVEMENT OF THE SPREADER COULD CAUSE DEATH OR SERIOUS INJURY.

SECTION IV

LOADING YOUR SPREADER

Before loading the spreader:

Center Covers: Center covers have different purposes depending on the type of spreader. Determine if your spreader has a full-length center cover, a half-length center cover, or no center cover.

Full-Length Center Covers: Spreaders with full-length center covers (WLS, Redhawk, CU, and BMS 5010 units) should have the inverted V-shaped center cover taken OUT of the spreader when spreading DAMP or Stockpiled materials or light, bulky materials.

Spreaders with full-length center covers should have the center cover put INTO the spreader when spreading GRANULAR (flowable) materials.

Note that the full-length center cover is used in shorter hoppers (10 ft and less) to prevent dry, flowable materials from flowing too fast from the rear gate.



CAUTION: FAILURE TO REMOVE THE FULL-LENGTH CENTER COVER WHEN SPREADING DAMP OR STOCKPILED LIME MAY RESULT IN DAMAGE TO THE CENTER COVER, CONVEYOR CHAIN, OR OTHER PARTS

Half-Length Center Covers: Spreaders with half-length center covers (BMS units except for the BMS 5010) should have the inverted V-shaped center cover put INTO the spreader when spreading DAMP or Stockpiled materials or when spreading GRANULAR (flowable) materials.

Spreaders with half-length center covers should have the center cover taken OUT of the spreader when spreading light, bulky materials.

Note that the half-length center cover is used in longer hoppers (more than 10 ft) to take weight off of the conveyor and help reduce stress on the driveline.

Spreader with No Center Cover: The Stoltzfus Litter Spreaders (SLS 8016, SLS 8020) are not intended to spread lime and are not supplied with a center cover.



CAUTION: MAKE SURE THAT THE HOPPER IS DRY BEFORE LOADING WITH FERTILIZER



CAUTION: DO NOT LEAVE THE SPREADER LOADED FOR EXTENDED PERIODS DURING FREEZING TEMPERATURES AS A FROZEN LOAD COULD RESULT IN SEVERE EQUIPMENT DAMAGE

SECTION V

OPERATING YOUR SPREADER

Use the rate chart provided with your spreader to determine the required combination of gear range setting, ground speed, and gate height to achieve the desired application rate.

WLS Series: All PTO Spreaders (PTO Powered Conveyor and Spinners): Body chain and spinners start when the PTO is turned on. Drive at a constant ground speed to achieve a consistent application rate.

Redhawk/CU Series: Ground Drive Spreaders with Hydraulic Spinners): Body chain starts when the press wheel is brought into contact with the moving ground wheels. Start the spinners before the conveyor starts. Spreader will compensate for changes in ground speed to maintain a consistent application rate.

BMS/SLS Series: PTO Conveyor, Hydraulic Spinners: Body chain starts when PTO is turned on. Start the spinners before the conveyor starts. Drive at a constant ground speed to achieve a consistent application rate.

Shear Hub Instructions (for Spreaders with PTO Conveyors):

Spreaders equipped with PTO driven conveyors are equipped with a shear hub to help protect the PTO driveline and conveyor.

⚠ DANGER: AT NO TIME SHOULD INSTALLATION BE DONE WITH ANYONE ON THE TRACTOR. SHUT THE TRACTOR OFF, REMOVE THE KEY AND DISCONNECT THE DRIVE LINE BEFORE DOING ANY SERVICE ON THIS MACHINE. FAILURE TO HEED MAY RESULT IN SERIOUS PERSONAL INJURY OR DEATH.

The conveyor is driven by two 3/8" grade 2 bolts. If the bolts shear, replace them with the same length 3/8" grade 2 bolts. DO NOT AUTOMATICALLY JUMP UP TO A HIGHER GRADE BOLT.



Recommended Procedure to Follow if the Bolts Shear:

Check for conveyor obstructions at the gate, in the hopper (if possible) and all along the return track. Check for bent or damaged conveyor slats that may be catching. Open the gate all the way to reduce stress on the driveline. Install new 3/8" grade 2 bolts and attempt to unload the hopper while checking for obstructions.

Once hopper is unloaded and any obstructions have been cleared, make sure the conveyor runs smoothly. Determine if center cover should be installed (see Loading Your Spreader section of manual). Reload spreader and attempt to spread normally. If bolts shear again without hopper or conveyor obstructions, you may install new 3/8" grade 5 bolts. As the shear bolt grade is increased the protection on the machine is going to decrease, and the potential for equipment damage is greater. If grade 5 bolts are shearing without hopper obstructions, it may be necessary to reduce the amount of material being loaded into the hopper. Do not install grade 8 bolts, as that will eliminate the protection provided by the shear hub.

Press Wheel Instructions (for Spreaders with Ground Drive Conveyors):

Ground drive spreaders are equipped with a press wheel to drive the conveyor. The press wheel is operated by a tractor cylinder circuit, and can be lowered or raised to start or stop spreading. Extend the press wheel cylinder fully to ensure contact with both ground wheels during operation.



Depending on the difficulty of the material being spread, it may be necessary to keep a slight downward pressure on the press wheel. Generally this will be required to break free a packed load of lime. Once the conveyor is moving the pressure on the press wheel can be reduced.

The press wheel operates best with 8 psi air pressure.

Never back up the spreader with the press wheel engaged.

SECTION VI

CALIBRATING YOUR SPREADER

Calibration consists of two steps:

1. Proper spread pattern of material across the field, and
2. Applying the correct amount of material to the field.

Spread Pattern Testing Overview:

1. Inspect and repair machine
2. Lay out test pans
3. Pull spreader across test pans
4. Collect material from pans
5. Examine spread pattern
6. Make any necessary adjustments
7. Repeat steps 3 - 6, if necessary.

⚠ WARNING: CONTACT WITH SPINNERS AND OTHER MOVING PARTS IS VERY DANGEROUS. GREAT CAUTION MUST BE USED WHEN WORKING AROUND THE SPREADER. ALL GUARDS MUST REMAIN IN PLACE. DO NOT ADJUST WHILE MACHINERY IS MOVING, WEAR EYE PROTECTION, AND AVOID DISCHARGE FROM SPINNERS. DO NOT RIDE ON MOVING SPREADER.

Step 1 – Inspect and Repair Machine:

- Inspect and repair/replace any component that is damaged or not working properly.
- Clean the rear end, spinners and blades.
- Determine the density (pounds per cubic foot) of material as accurately as possible.
 - To determine density (pounds per cubic foot), weigh 5 gallons of material and multiply by 1.50. Remember not to include the weight of the container.
- Fill the hopper with enough material to cover the rear gate.

Step 2 – Lay out Test Pans:

In the field, lay out 11 pans in a level row. One pan should be on the center line to be driven and five should be on each side, ten feet apart. This will catch material up to 50 feet on each side of the spreader when you drive over the center pan.

We recommend using the spread pattern test kit described below.

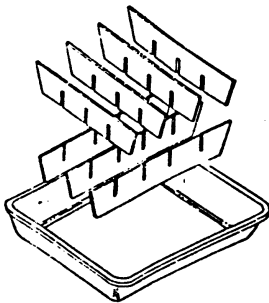

Contents of Spread Pattern Test Kit (Part # 29754)			
Qty.	Description	Qty.	Description
11	Plastic Pans	1	Funnel
33	Long Divider	1	Test Kit Instructions
44	Short Divider	100	Data Sheets
1	Tube Rack Assy.	9	Flags
1	Tool Box		

Do not test if wind velocity is over 5 mph. If a wind exists, try to spread directly with or into the wind.

Before starting across the pans, drive about 500 feet to settle the material onto the chain and against the gate.

Step 3 – Pull Spreader Across Test Pans:

- Open the gate according to the application rate chart on the spreader. You should calibrate your spreader at the same rate you will actually be applying to the field.
- Starting about 100 feet from the pans, start the conveyor and spinners and begin spreading.
- Spread across the pans and continue for another 100 feet.

Step 4 – Collect Material from Pans:

- The contents of the test pans must now be emptied into a set of test tubes, or equal size containers. One pan per container.
- The spread pattern test kits contain 11 test tubes with a rack for standing the tubes and measuring the volume in each.

Step 5 – Examine Spread Pattern:

- Line the test tubes up in the same order as the pans.
- The level of the material in the tubes gives you a clear picture of the spread pattern on the ground.
- You will find it very helpful to graph the results. The spread pattern test kits include graph paper for this purpose.

Acceptable spread patterns are shown below:

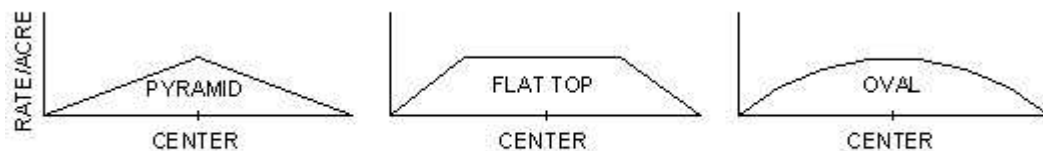

The recommended driving method is shown below:

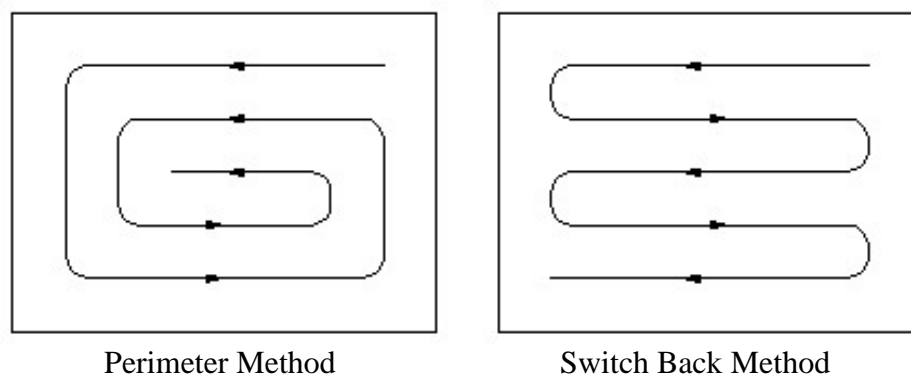

It is recommended that the perimeter driving method be used whenever possible, as this method compensates for non-symmetrical patterns by blending the right side of the pattern with the left side of the adjacent pattern and vice versa. However, when the only practical driving method is the switch back method, the driver should be aware that non-symmetrical patterns are amplified by blending right side on right and left side on left.

The ideal spread pattern overlap is shown below:

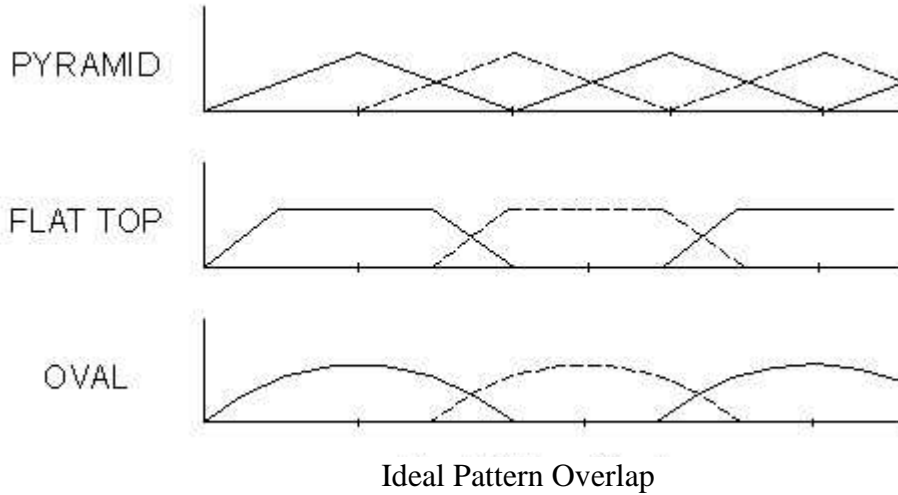

Step 6 – Make any Necessary Adjustments:

As the material falls out of the hopper onto the spinners, the deflectors (especially B), should guide the material so the center of the flow hits the spinner disc beside (or slightly in front of) the spinner shaft. This is an important adjustment to make when switching between high rates of lime and low rates of fertilizer.

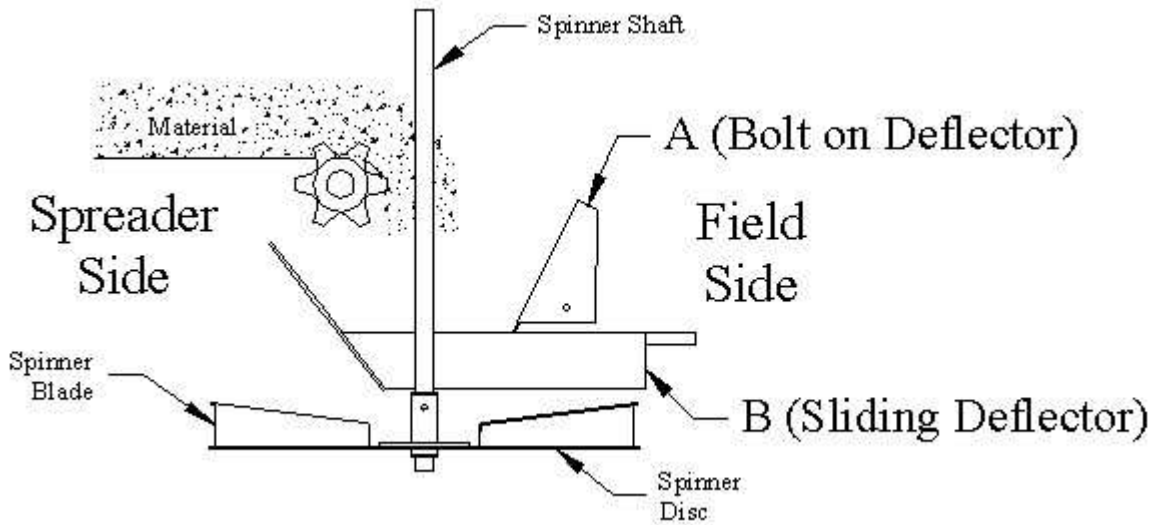

⚠ CAUTION: SPREADER MUST BE SPREAD PATTERN TESTED PRIOR TO PUTTING INTO USE EACH SEASON. DUE TO MATERIAL VARIATIONS, SPREAD PATTERN TESTING IS RECOMMENDED WHENEVER MATERIALS OR SPREAD RATES ARE CHANGED. STOLTZ MFG., LLC CANNOT BE LIABLE FOR CROP LOSS DUE TO AN IMPROPERLY ADJUSTED SPREADER.

The basic adjustments for changing your spread pattern are shown in the drawings below. Sliding deflector B is the primary means of adjustment. If that does not prove adequate, the spinner blades can also be pivoted to make the final adjustments to the pattern.

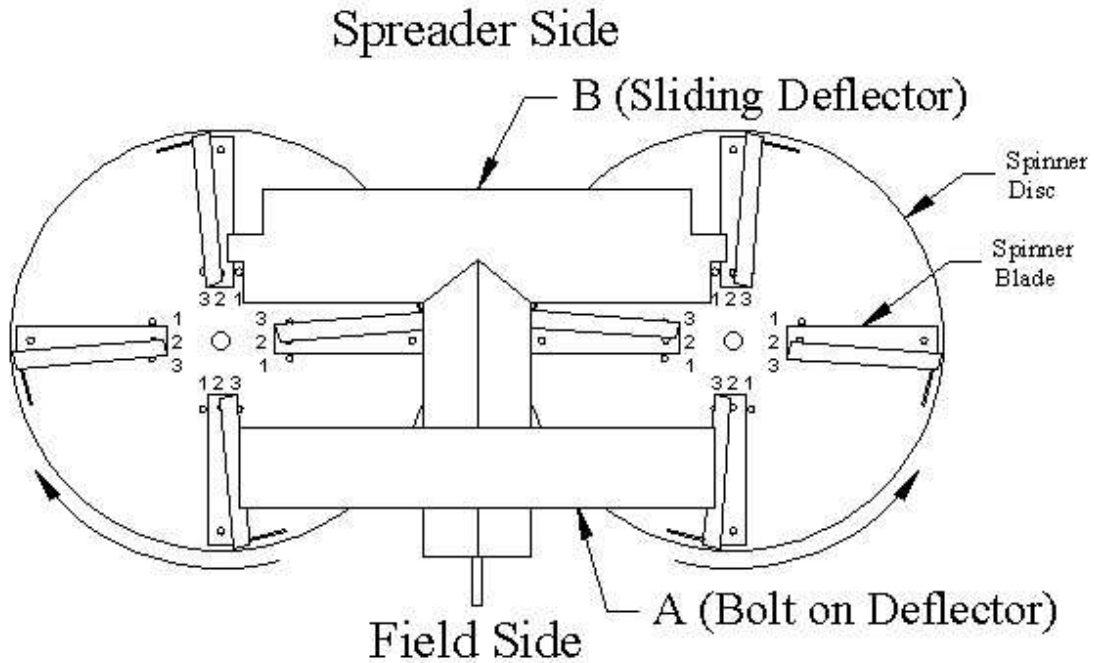

To reduce the side and increase the center of the spread pattern, push adjustable deflector B towards the spreader. To increase the side and decrease the center of the spread pattern, pull adjustable deflector B towards the field side.

Unacceptable spread patterns, along with corrective actions, are shown below:

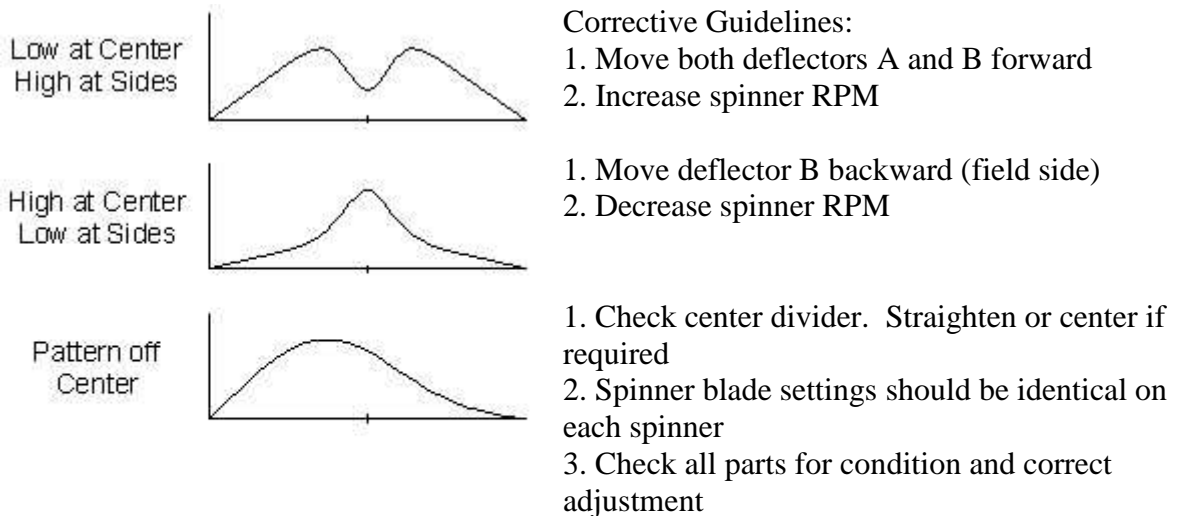

If adjusting the deflector does not solve the problem, the spinner blades can be moved to correct the spread pattern (note: only adjust 1 blade at a time on each spinner disc):

- Blades moved to hole #1 will produce a higher-center pattern
- Hole #2 is the standard setting
- Blades moved to hole #3 will produce a higher-side pattern

SECTION VII

APPLICATION RATE CALCULATIONS

Note: For best results, use lower speed body chain drive and greater gate opening to reduce resistance on chain and stress on the gate.

Density Calculation:

Weigh one gallon of the material (remember to subtract the weight of the container). Multiply that weight by 7.5 to get the density in pounds per cubic foot.

Alternatively, weigh a 5 gallon bucket of the material (remember to subtract the weight of the container). Multiply that weight by 1.5 to get the density in pounds per cubic foot.

If the density (pounds per cubic foot) of your material is different from those on the chart, adjust the rates on the chart as follows:

Fertilizer	Add or subtract to the 65 lb numbers
80 lb/cu. ft.	Add 23%
75 lb/cu. ft.	Add 15%
70 lb/cu. ft.	Add 8%
65 lb/cu. ft.	Use the numbers on the chart
60 lb/cu. ft.	Subtract 8%
55 lb/cu. ft.	Subtract 15%
50 lb/cu. ft.	Subtract 23%

Lime	Add or subtract to the 100 lb numbers
110 lb/cu. ft.	Add 10%
100 lb/cu. ft.	Use the numbers on the chart
90 lb/cu. ft.	Subtract 10%

The rates on the chart are calculated based on a 40 foot driving interval. If your material will not spreader 40 feet, your rate per acre will increase as follows:

Driving on 35 ft intervals increases the chart rates by 12.5%

Driving on 30 ft intervals increases the chart rates by 25%

Driving on 25 ft intervals increases the chart rates by 37.5%

Bulk Material Spreader (BMS) Rate Charts:

Use the following chart for initial spreader settings:

540 RPM power takeoff:

30 inch chain 40 ft spread 100 lb/cf material 540 PTO											
Gate Height	LOW RANGE			speed (mph)	HIGH RANGE			speed (mph)	LOW/LOW RANGE		
	5	7.5	10		5	7.5	10		5	7.5	10
12	8592	5728	4296		15752	10501	7876		5012	3341	2506
11	7876	5251	3938		14439	9626	7219		4594	3063	2297
10	7160	4773	3580		13126	8751	6563		4177	2784	2088
9	6444	4296	3222		11814	7876	5907		3759	2506	1879
8	5728	3819	2864		10501	7001	5251		3341	2228	1671
7	5012	3341	2506		9188	6126	4594		2924	1949	1462
6	4296	2864	2148		7876	5251	3938		2506	1671	1253
5	3580	2387	1790		6563	4375	3282		2088	1392	1044
4	2864	1909	1432		5251	3500	2625		1671	1114	835
3	2148	1432	1074		3938	2625	1969		1253	835	626
2	1432	955	716		2625	1750	1313		835	557	418
1	716	477	358		1313	875	656		418	278	209
65 lb/cf material											
12	5585	3723	2792		10239	6826	5119		3258	2172	1629
11	5119	3413	2560		9385	6257	4693		2986	1991	1493
10	4654	3103	2327		8532	5688	4266		2715	1810	1357
9	4188	2792	2094		7679	5119	3839		2443	1629	1222
8	3723	2482	1862		6826	4550	3413		2172	1448	1086
7	3258	2172	1629		5972	3982	2986		1900	1267	950
6	2792	1862	1396		5119	3413	2560		1629	1086	814
5	2327	1551	1163		4266	2844	2133		1357	905	679
4	1862	1241	931		3413	2275	1706		1086	724	543
3	1396	931	698		2560	1706	1280		814	543	407
2	931	621	465		1706	1138	853		543	362	271
1	465	310	233		853	569	427		271	181	136
50 lb/cf material											
12	4296	2864	2148		7876	5251	3938		2506	1671	1253
11	3938	2625	1969		7219	4813	3610		2297	1531	1149
10	3580	2387	1790		6563	4375	3282		2088	1392	1044
9	3222	2148	1611		5907	3938	2953		1879	1253	940
8	2864	1909	1432		5251	3500	2625		1671	1114	835
7	2506	1671	1253		4594	3063	2297		1462	975	731
6	2148	1432	1074		3938	2625	1969		1253	835	626
5	1790	1193	895		3282	2188	1641		1044	696	522
4	1432	955	716		2625	1750	1313		835	557	418
3	1074	716	537		1969	1313	984		626	418	313
2	716	477	358		1313	875	656		418	278	209
1	358	239	179		656	438	328		209	139	104

Rate chart is for initial settings only. Actual results will vary with material.

1000 RPM power takeoff:

30 inch chain 40 ft spread 1000 PTO 100 lb/cf material											
Gate Height	LOW RANGE			speed (mph)	HIGH RANGE			speed (mph)	LOW/LOW RANGE		
	5	7.5	10		5	7.5	10		5	7.5	10
12	9281	6188	4641		15188	10125	7594		8121	5414	4061
11	8508	5672	4254		13922	9281	6961		7444	4963	3722
10	7734	5156	3867		12656	8438	6328		6768	4512	3384
9	6961	4641	3480		11391	7594	5695		6091	4061	3045
8	6188	4125	3094		10125	6750	5063		5414	3609	2707
7	5414	3609	2707		8859	5906	4430		4737	3158	2369
6	4641	3094	2320		7594	5063	3797		4061	2707	2030
5	3867	2578	1934		6328	4219	3164		3384	2256	1692
4	3094	2063	1547		5063	3375	2531		2707	1805	1354
3	2320	1547	1160		3797	2531	1898		2030	1354	1015
2	1547	1031	773		2531	1688	1266		1354	902	677
1	773	516	387		1266	844	633		677	451	338
65 lb/cf material											
12	6033	4022	3016		9872	6581	4936		5279	3519	2639
11	5530	3687	2765		9049	6033	4525		4839	3226	2419
10	5027	3352	2514		8227	5484	4113		4399	2933	2199
9	4525	3016	2262		7404	4936	3702		3959	2639	1980
8	4022	2681	2011		6581	4388	3291		3519	2346	1760
7	3519	2346	1760		5759	3839	2879		3079	2053	1540
6	3016	2011	1508		4936	3291	2468		2639	1760	1320
5	2514	1676	1257		4113	2742	2057		2199	1466	1100
4	2011	1341	1005		3291	2194	1645		1760	1173	880
3	1508	1005	754		2468	1645	1234		1320	880	660
2	1005	670	503		1645	1097	823		880	587	440
1	503	335	251		823	548	411		440	293	220
50 lb/cf material											
12	4641	3094	2320		7594	5063	3797		4061	2707	2030
11	4254	2836	2127		6961	4641	3480		3722	2481	1861
10	3867	2578	1934		6328	4219	3164		3384	2256	1692
9	3480	2320	1740		5695	3797	2848		3045	2030	1523
8	3094	2063	1547		5063	3375	2531		2707	1805	1354
7	2707	1805	1354		4430	2953	2215		2369	1579	1184
6	2320	1547	1160		3797	2531	1898		2030	1354	1015
5	1934	1289	967		3164	2109	1582		1692	1128	846
4	1547	1031	773		2531	1688	1266		1354	902	677
3	1160	773	580		1898	1266	949		1015	677	508
2	773	516	387		1266	844	633		677	451	338
1	387	258	193		633	422	316		338	226	169

Rate chart is for initial settings only. Actual results will vary with material.

Changing Gear Ranges:

Gear ranges are selected by moving the roller chain between the different sets of sprockets.

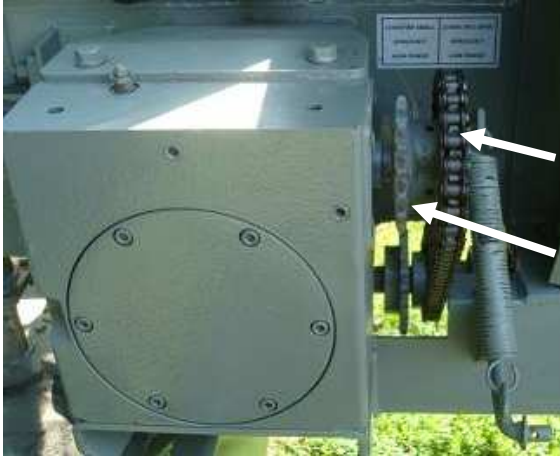

Low Range: Small sprocket on driveline to large sprocket on gearbox input.

High Range: Large sprocket on driveline to small sprocket on gearbox input.

Driveline Gearbox on right side of spreader

For BMS spreaders with the optional Low Rate (fertilizer) Kit:



Low & High Range: Chain goes on inside set of sprockets. Choose range at driveline gearbox as shown above.

Low/Low Range: Chain goes on outside set of sprockets plus select Low Range at driveline gearbox as shown above.

Low Rate Kit on left side of spreader

SECTION VIII

LUBRICATION AND MAINTENANCE

Grease Zerks: One or two shots with a hand-held grease gun is sufficient to lubricate and to keep dust and moisture out of the bearings. **DO NOT OVER LUBRICATE!** This may force out bearing seals allowing dust and moisture to enter and thus cause excessive wear.

Telescoping Chain Tighteners & Drag Chain Slack: Use telescoping tighteners to adjust drag chain slack. Measure the distance from the front idler shaft to the point where the drag chain first lifts off the return track. A distance of 18 inches should be maintained between these two points. Adjust the chain accordingly to obtain the right measurement. Be sure both sides are adjusted equally. If chain tighteners are near the point of maximum adjustment, retract the tighteners all the way. Remove as many links as necessary and readjust chain. Note: Remove links in pairs only. Retighten to proper adjustment.

Check Wheel Bearings: Thoroughly clean all the parts in solvent and check for rough bearings or cracked spindles. Clean and inspect the brake drums, linings and mechanisms (when applicable). Repack bearings by squeezing grease between the rollers. Do not over-tighten spindle nut when reassembling (Note: Do NOT remove wheel hubs with wheels and tires attached).

Driveline Gearbox (if equipped): The driveline gearbox is fill-for-life and does not need oil changes. The gearbox is filled with a polyalkaline glycol (PAG) synthetic oil such as Mobil Glygoyle 460. Please note that PAG oils are NOT COMPATIBLE with any other types of oil, and oils must not be mixed. If changing a unit to another type of oil, the unit must be thoroughly flushed out with the new oil.

Spinner Gearboxes (if equipped): An initial oil change should be made after the first 50 hours of operation. Subsequent oil changes should be made at 2000 hour intervals or annually, whichever comes first.

Spinner Shafts: Check chain coupler set screws for tightness. Check bearing locking collars for tightness.

Suspension: Give the zerks on the walking beam suspension one or two shots of grease daily with a hand-held grease gun. Grease the spring bolts on spring suspensions

Drawbar: Regularly inspect the drawbar for wear and damage. If wear exceeds 1/8" (0.125"), replace the drawbar. Inspect the mounting fasteners and ensure they are properly tightened.

END OF SEASON STORAGE

Following a few simple guidelines for end of season storage will help prolong the life of your spreader:

1. Clean all material out of the hopper.
2. Sand and paint all bare spots.
3. Perform maintenance and lubrication.
4. Oil tank (if equipped) should be drained, flushed, and refilled annually or whenever oil shows any signs of breaking down. Discoloration of oil is one sign of breakdown. Oil is universal tractor fluid.
5. Change oil filters (if equipped).
6. Check all bearings. If shaft can be moved 1/32" in the bearing, replace the bearing. Make sure locking collars are tight.
7. Check sprockets. Steel sprockets that are worn to a sharp point should be replaced. Cast iron sprockets that show excessive wear should be replaced.
8. Check set screw tightness on spinner shaft chain coupler sprockets.
9. Store out of weather. Spreaders should be stored under a roof if possible.
10. If spreader is stored outside, lubrication recommendations should be performed once a month.

SECTION XIV

REPLACEMENT PARTS LISTS

When ordering parts, refer to the drawings that follow.

Using the item number on the drawings, look up the part number on the part number list for that drawing

Call your local Stoltzfus Dealer to order parts. If you purchased your spreader directly from the factory, call 610-350-4322 to order parts.

All parts will be shipped UPS unless they are too big, or you wish to make other arrangements.

All prices are FOB Morgantown, PA. Freight charges will be extra.

All appropriate federal, state and local taxes will also be added.

Minimum parts order for shipping: \$ 10.00.

A 10 percent restocking charge will be added to all returned parts. No restock charge will be charged for exchanged parts.

Note: Some parts are labeled NAP - non-available part. This means that the part (such as nuts, bolts, cotter pins, etc) should be available locally.

SECTION XV

OPTIONS/CUSTOM COMPONENTS (If Applicable)

NOTES:

Contact Information:

PHONE: 800-843-8731
+610-350-4322 international
Fax: 610-350-4216
email: info@stoltzmf.com